

# RatioMatic Burners

## Model RM300 Version 3.00

### Main Specifications - RM300

PARAMETER		SPECIFICATIONS			
		English		Metric	
		Capacity @ Chamber Pressure			
		BTU/hr	@ "w.c.	kW	@ mbar
Maximum input	60 Hz packaged blower	3,650,000	-5.0	1070	-12,4
		3,320,000	-2.0	970	-5,0
		3,100,000	0.0	910	0,0
		2,840,000	2.0	830	5,0
		2,400,000	5.0	700	12,4
	50 Hz packaged blower	3,550,000	-5.0	1040	-12,4
		3,220,000	-2.0	940	-5,0
		3,000,000	0.0	880	0,0
		2,740,000	2.0	800	5,0
		2,300,000	5.0	670	12,4
Note: Contact factory for varying chamber pressures or pressures outside the range: -5.0 to 5.0" w.c. (-12,4 to 12,4 mbar)					
Minimum input		BTU/hr		kW	
		65,000		19	
Main gas inlet pressure • fuel pressure at ratio regulator inlet		Natural gas Propane or Butane		"w.c.	
		20 to 55 20 to 35		mbar 50 to 140 50 to 90	
High fire flame length • measured from the outlet end of the combustor		Natural gas Propane or Butane		inches	
		60 in 65 in		mm 1500 mm 1650 mm	
Maximum chamber temperature		Alloy tube Block & Holder		°F	
		1500 1900		°C 815 1040	
Flame detection		Flame rod or UV scanner			
Fuel		Natural Gas, Propane or Butane. For any other mixed gas, contact Eclipse Combustion for orifice sizing			

- All information is based on laboratory testing. Different chamber size and conditions will affect the data.
- Maximum inputs are given for the standard combustion air blower without an air filter.
- All inputs based upon gross calorific values and standard conditions; 1 atmosphere, 70° F ( 21°C).
- Eclipse reserves the right to change the construction and/or configuration of our products at any time without being obliged to adjust earlier supplies accordingly.



Eclipse Combustion

ISO 9001 Registered

## Performance Graphs RatioMatic RM300

### Control & Operation Zone

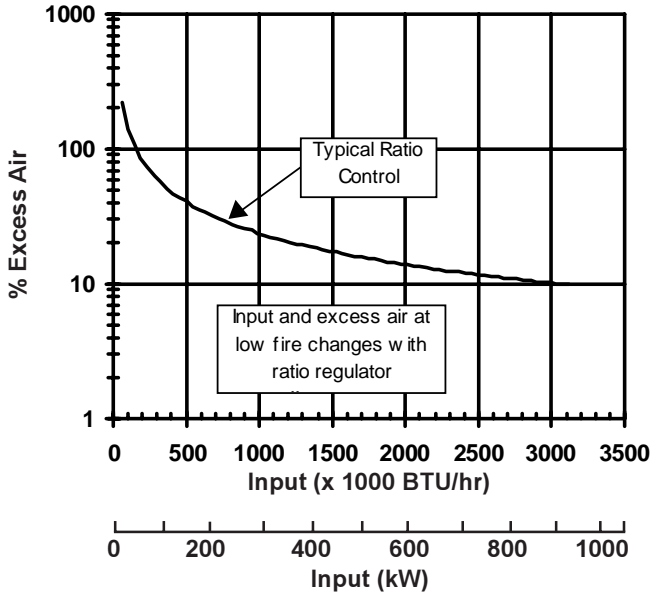

### NO<sub>x</sub> Emission Data

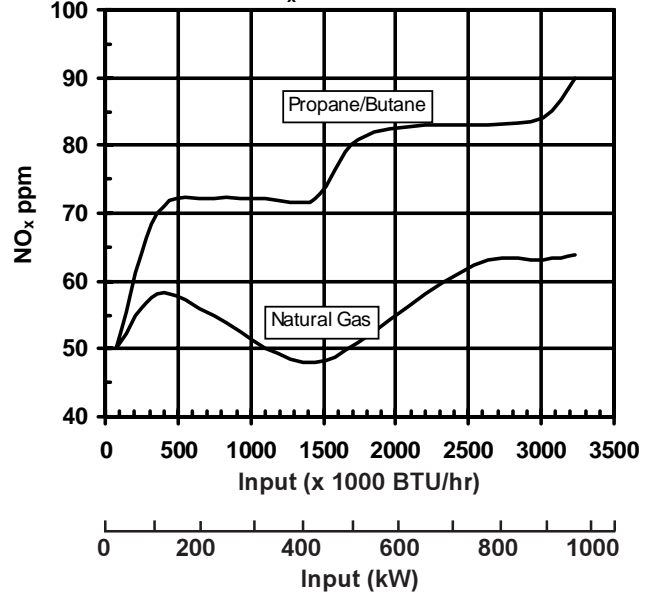

#### Notes on emission data

**NO<sub>x</sub> emission data is given for:**

- Ambient combustion air ~70° F (20° C)
- Less than 1000°F (540°C) firing chamber
- Minimal process air velocity
- Low fire input adjusted to 65,000 BTU/hr (19kW)
- ppm volume dry at 3% O<sub>2</sub>
- Neutral chamber pressure

**Emissions are influenced by:**

- Chamber conditions
- Fuel type
- Firing rate
- Ratio regulator adjustment
- Combustion air temperature

**CO emission is largely influenced by chamber conditions.  
Contact your local Eclipse Combustion representative for an  
estimate of CO emission on your application.**

### Fuel Orifice Δ P vs. Input

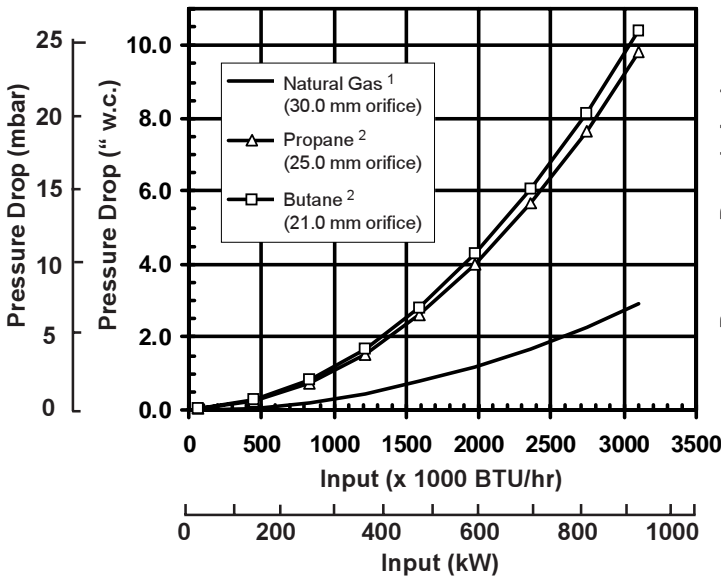

### Air Δ P vs. Air Flow

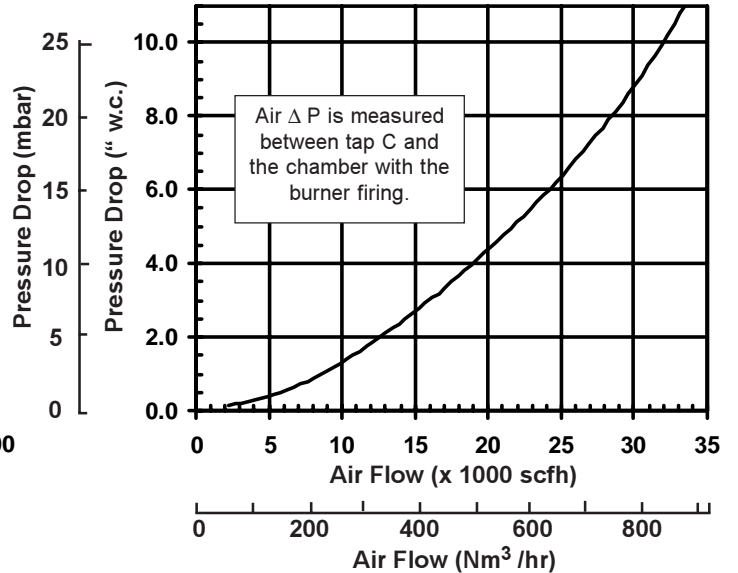

<sup>1</sup> Natural gas ΔP measured between taps B and D.

<sup>2</sup> Propane or Butane ΔP measured between tap B and chamber.

# Dimensions-RM300

## Dimensions mm (in)

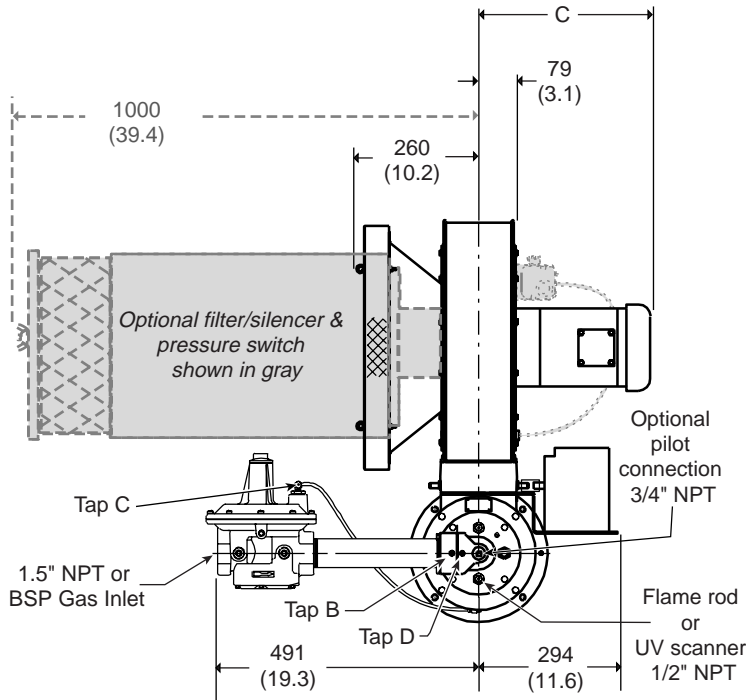

	A	B	C
50 Hz	614 (24.2)	704 (27.7)	350 (13.8)
60 Hz	555 (21.8)	650 (25.6)	332 (13.1)
60 Hz (Auto)	555 (21.8)	650 (25.6)	383 (15.1)

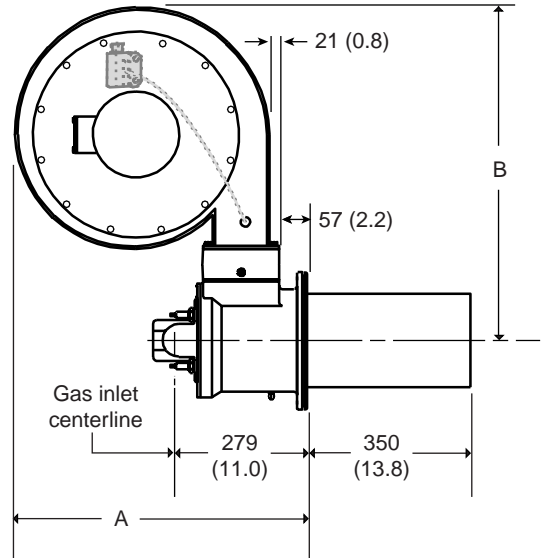

Weights	
Packaged Burner	61 kg (135 lb.)
Filter Silencer	24 kg (52 lb.)

Note: See Price List 110 for available spare parts.

## Combustor types

### Alloy tube

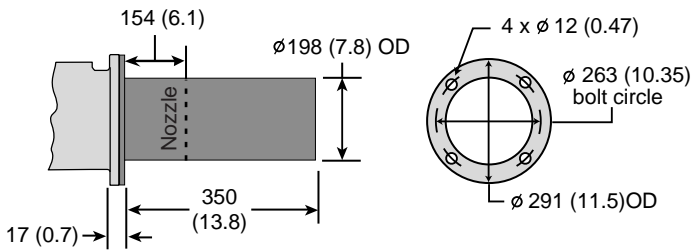

### Block & Holder

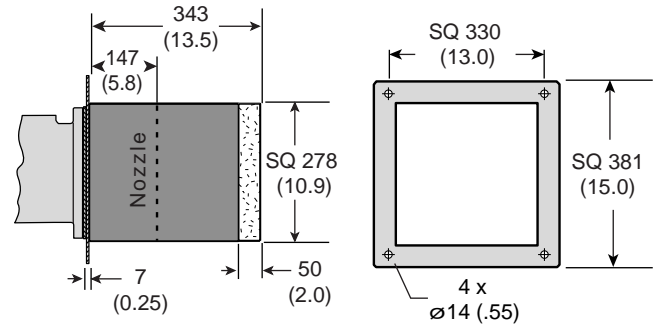

## Burner configuration

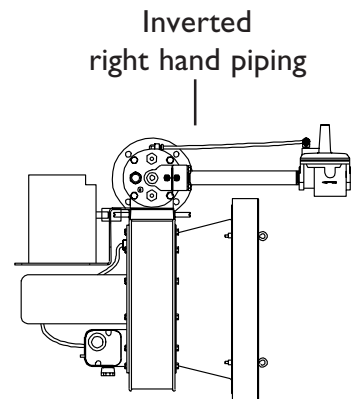
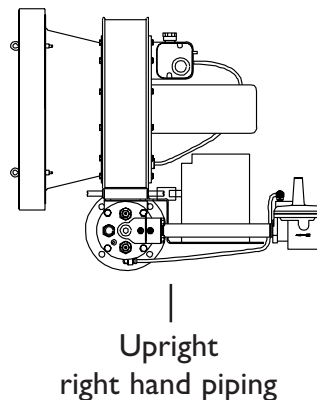
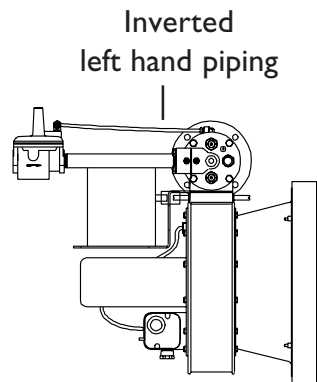
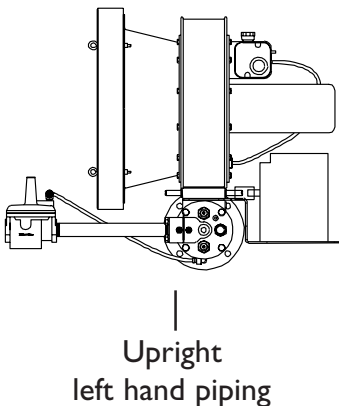



**Offered By:**

Power Equipment Company  
2011 Williamsburg Road  
Richmond, Virginia 23231  
Phone (804) 236-3800  
Fax (804) 236-3882

---

[www.peconet.com](http://www.peconet.com)